



ACCURL MACHINE TOOLS(CHINA)

Industrial Park in Bowang Ma'anshan,
Anhui, China
T : +86 188 5555 1088
T : +86(0)555 2780 553
E-Mail : info@accurl.com
www.Accurl.com

AGENT :



HYDRAULIC IRONWORKERS & PUNCHING MACHINES

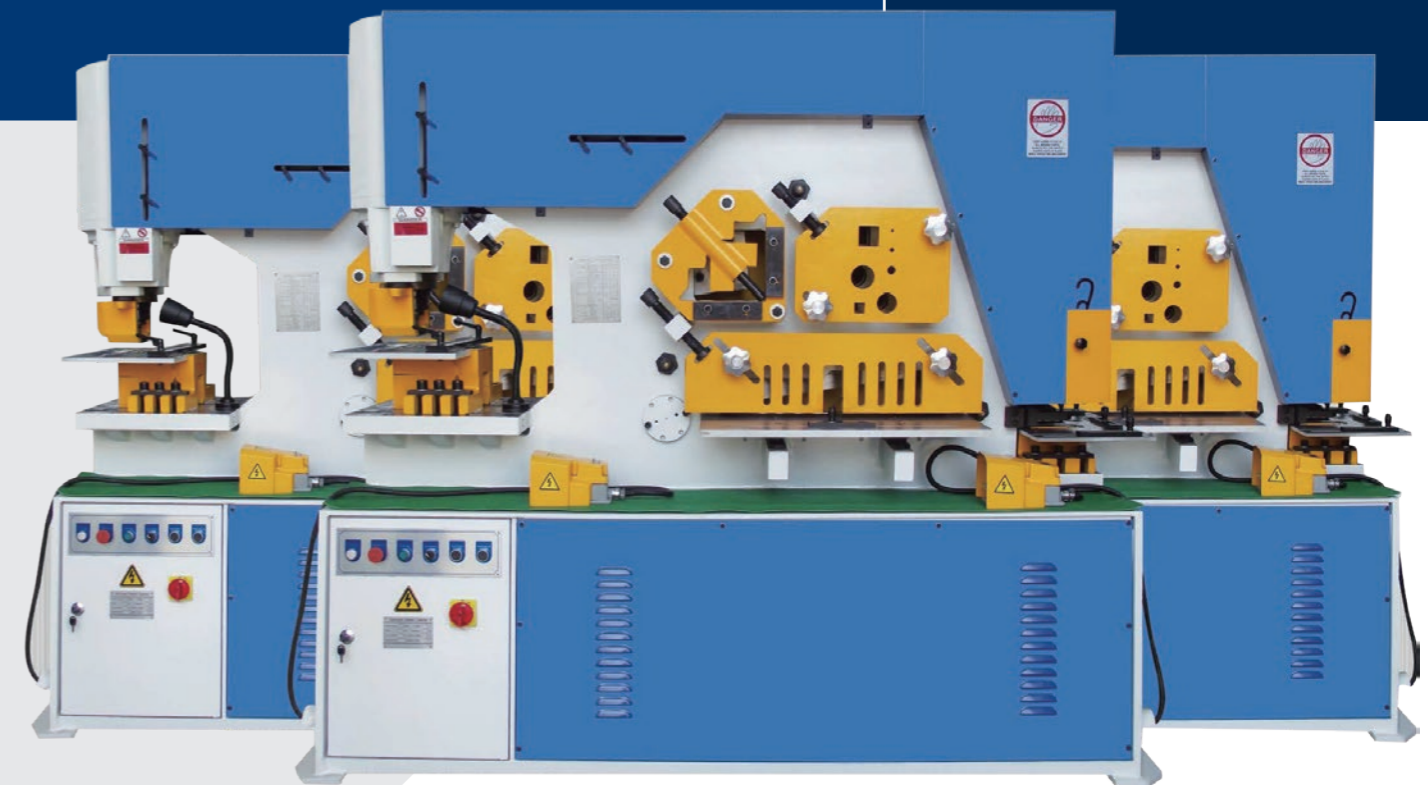

Multi-Function / Excellent Quality / Economical Investment



ISO 9001

INTRODUCTION

With a highly dedicated team, Accurl Machine Tools has been specializing in the manufacturing of hydraulic ironworkers, punching machines, bending machines, and other hydraulic machinery and equipment for over 30 years. Total customer satisfaction is our number one goal. We are passionate about providing engineering excellence in everything we do, and we are dedicated to manufacturing world-class, high-value products for our global customers.

Product Differentiation

Accurl is ISO-9001 certified by BVQI, and our products meet the CE safety requirements and regulations. We relentlessly seek continuous improvement and product development. Currently Accurl has the broadest range of ironworker and punching machine models compared to any other manufacturer. Accurl product advantages: Durability, Accuracy, and Versatility. Besides our very popular single and dual operator models, we have introduced the K-series, a new line of ironworker with vertical movement at all stations. The center beam in the entire range of K-series moves in straight up and down motion to provide less deformation, better results and longer tooling life.



Quality Control

Quality of the highest standard is the key factor in success. All key components of our ironworkers, punching machines, etc. are made in-house at our modern plant and automated production lines. We use the latest control system to ensure highly efficient production, and the quality assurance team measures and tests each component to ensure precision standards of machined parts are met or surpassed. Finally, before shipping, each complete machine goes through intensive quality and performance tests to make absolute sure it meets our strict company quality standards before it arrives at the customer's operation.



Sales and Service

Our global sales network covers almost 50 countries in Europe, Australia, North America, Southeast Asia, the Middle East and more. This coverage, combined with the quality of our machines, makes Accurl one of the best choices when it comes to metal forming. In this highly competitive international market, Accurl's market share continues to grow. Thank you to our many and growing list of satisfied customers for your continued support. Sunrise is now one of the leading brands in the fabricating industry. We look forward to your continued support and comments -- together we will push quality at Accurl ever higher.

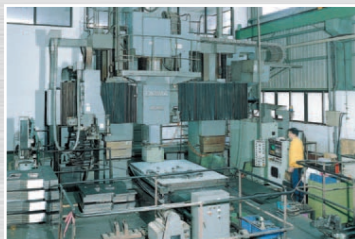

Accurl Hydraulic Ironworkers are designed with multiple functions to save labor, time, energy and cost. This allows Accurl Ironworkers to meet the diversified needs of the metal fabricating industry.

Maximum efficiency and long life is guaranteed by using the latest manufacturing methods, including powerful CAD design, modern production line with CNC equipment and continuous quality control.

Each work station is equipped with specially designed hold-downs to ensure safety while providing precision and ease of use. These ironworkers are the most economical and efficient machines in the industry for the manufacturing of metal products.

All Accurl ironworkers and punching machines come standard with a low pressure tool alignment mode. The operator can use the JOG mode to run the machine in low pressure and low speed for tool alignment, blade changes and maintenance operations. This greatly improves operator safety and prevents tool damage in case of mis-alignment.

Key features on the dual cylinder models:

The dual cylinder models feature a separate cylinder for independent operation from shearing stations.



The cylinder ram is guided at three positions to provide extra support and absorb side-load forces for added protection of cylinder seals.

Cylinder ram with flat surface for rigid guiding and to ensure proper alignment of tool.

Keyed punch ram to ensure alignment of shaped tooling.



The base of the machine is made from welded channel in a grid pattern for a rigid machine foundation.







The punching station features a large cylinder mounting plate to ensure maximum cylinder support under heavy load. The punching base is one solid plate with T-slot grooves for universal tool fixture.

The frame of the machine is a monoblock construction that integrates both bolts and welding reinforcement to provide maximum frame structure rigidity.

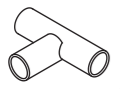
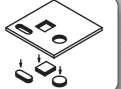
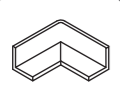
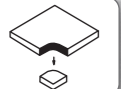
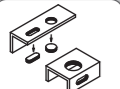

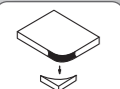
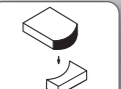
FEATURES

HYDRAULIC IRONWORKERS & PUNCHING MACHINES

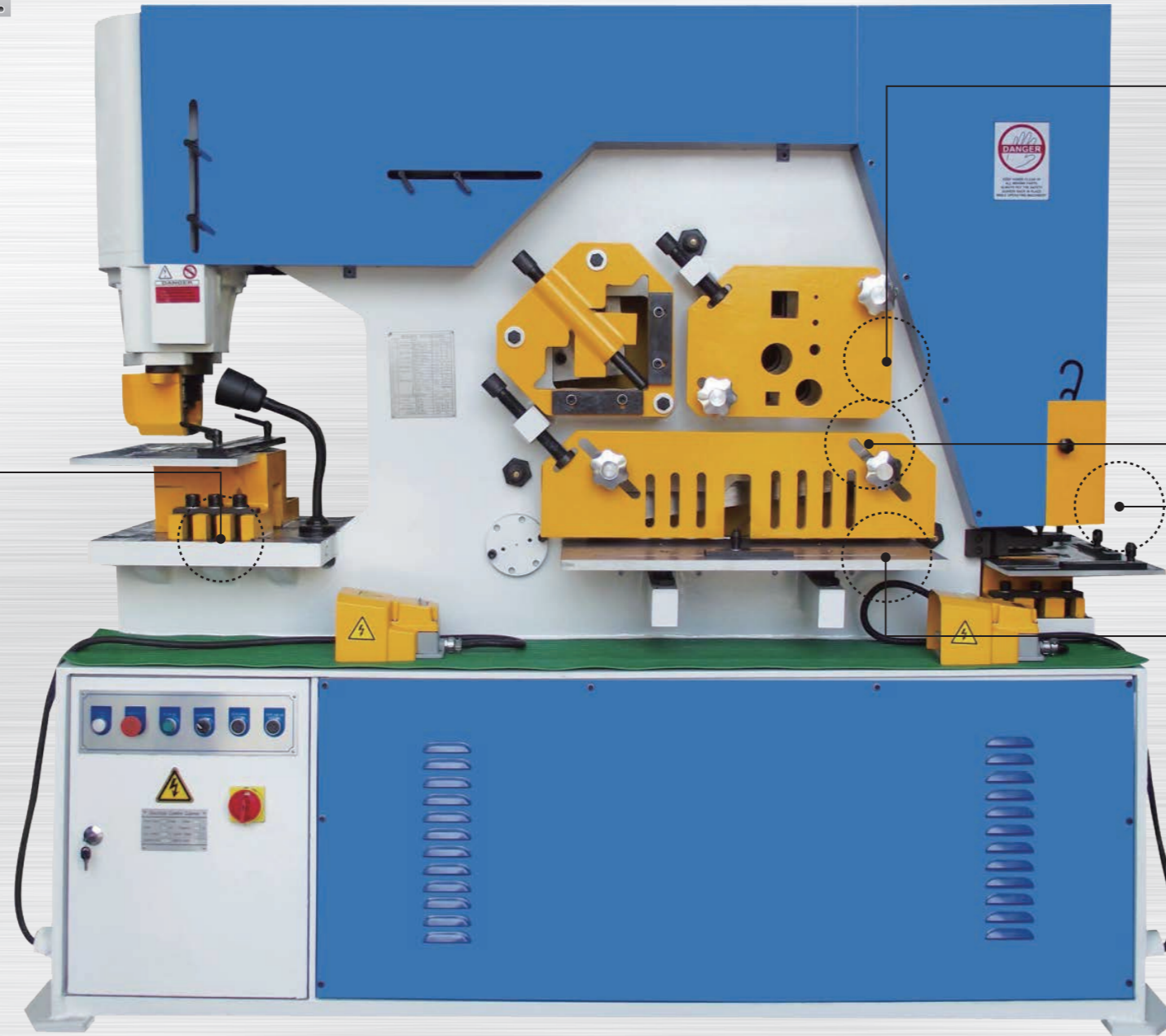
	
*Pipe Notching	Punching
	
*Angle Bending	*Radius Corners
	
Punching	*Pipe Punching
	
*Rounding off Corners	*Cutting and Rounding off
	
*Press Brake	*Bilateral Rounding off

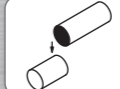
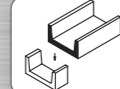
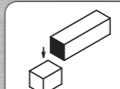
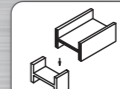

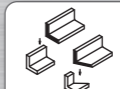
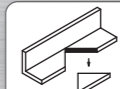
	
Round Bar Shear	*Channel Shear
	
Square Bar Shear	*I Beam Shear

			
Angle Shear	*Vee Notching	Notching	Notching

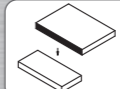
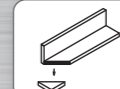
	
Flat Bar Shear	Angle Miter Shear



The use of name-brand hydraulic components ensure excellent reliability of the hydraulic system.



Electric cabinet with low 24 volt DC control circuit provides full protection and safety.

IW-165SD

* : Optional tooling

WORK STATIONS

Punching Station

- A full range of punches and dies are available for various punching needs.
- Quick change retaining nut system for fast punch tooling change.
- Thoughtfully designed stripper for visibility, safety and ease of use.

- A large 2-piece table with scales and gauging stops is standard on all models.
- Stripper with interchangeable plates of various openings to minimize deformation is standard on all models.
- Optional hydraulic stripper is available on dual-cylinder ironworkers and all punching machines.

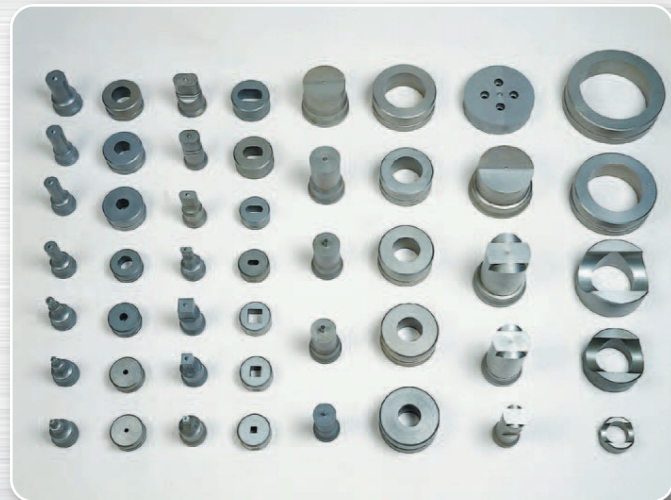

*Punches and dies are sold separately.



*Standard dual-opening die block for up to 50mm round punch and die.



Overhang die holder for punching channel flanges and angles. (optional on single cylinder models)

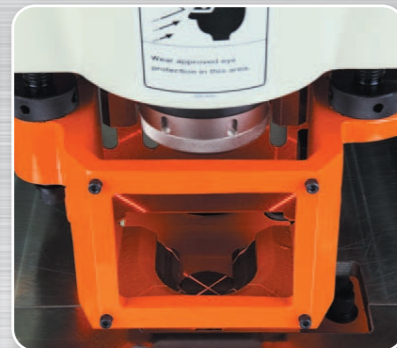

*Laser alignment system for more accurate positioning of marked parts.



*Goose-neck die holder for punching channel flanges and webs.



*Urethane spring stripper for minimal deformation. Safety cover removed for showing.



*Pipe notcher.



*Oversize punch attachment. Safety cover removed for showing.



*Multi-stop gauge table. (S/SD/KD and PM models only)

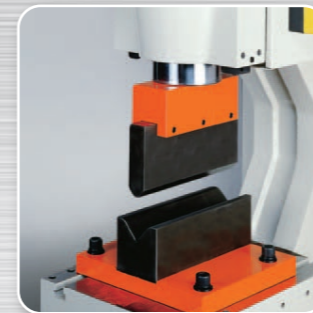

*Single vee press brake.



*Multi vee press brake.



*Large vee-notcher. (Punch side)



*Angle bending press.

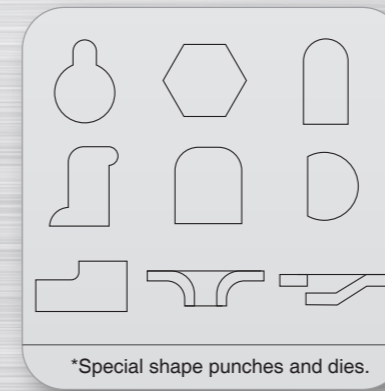

*Special shape punches and dies.



*Optional Semi-Automatic CNC Tables with 1000x400mm travel.

* : Optional tooling

WORK STATIONS

Flat Bar Shearing Station

- Specially machined upper blade to give a clean shear with minimum distortion.
- Lower blade has four usable cutting edges.
- Variable degree miter-cutting on angle flange.
- Easily adjustable hold-down.
- Support table with guides for accurate positioning.

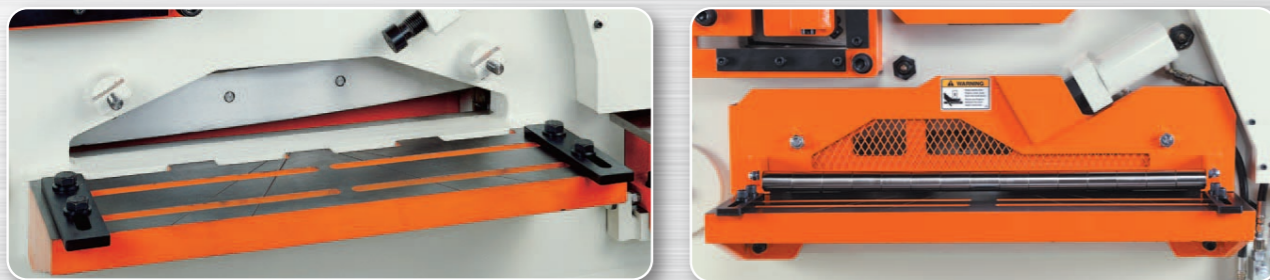

*Optional hydraulic hold-down for double cylinder ironworkers. (Standard on IW-165SD)

Bar Shearing Station

- One hold-down for various sizes of square bar shearing and round bar shearing.
- Optional channel and section bar shear tooling is available for most models. (See specification chart for details)

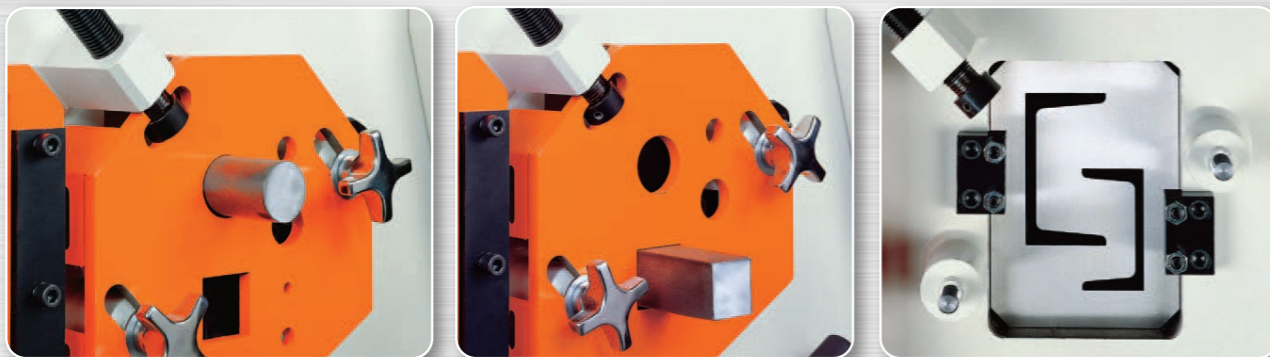

*Channel blades. (optional)

Angle Shearing Station

- Single shear with no material loss and minimal deformation.
- 45° miter-cut is easy and clean.
- Stationary blades with four usable cutting edges.
- Selectable corner radii on moving blades for optimum results on small or large angles.



*Optional hydraulic hold-down for angle shear.

Notching Station

- Ideal for notching of flat bars and angles.
- Electrically interlocked safety guard for maximum safety and visibility.
- Gauging table included with stops for precise positioning.

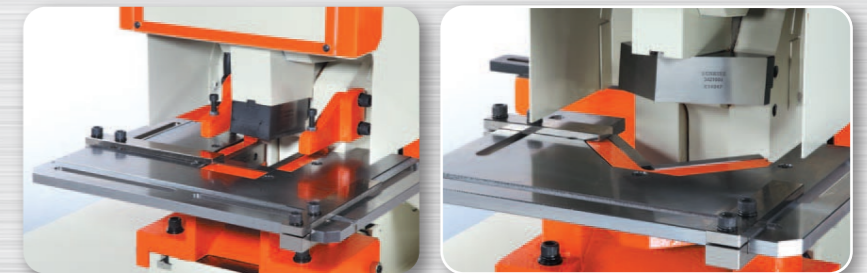

*Optional vee-notcher.

Other Included Features

1. Three limit switches enable setting of short notch stroke to improve efficiency. (on IW-50A, IW-60H and S/SD models)
2. Magnetic base LED work light for safer operation. (optional on IW-45M)
3. 1000mm electric backgauge for higher efficiency in repetitious work. The gauge extension is available depending on request.



*Optional on IW-45M, IW50A, IW-60H.

S/SD SERIES

Double Cylinder Models

The double cylinder "S/SD" series are in the Accurl tradition of well engineered ironworkers built for high power, quality, and reliability. These ironworkers have two control foot pedals, and separate operations can be safely performed simultaneously. The low pressure setting for tool change provides maximum operation safety. The long punching cylinder stroke and deep throat enable mounting a wide range of special equipment. The large punching base with the "T-slot" mounting provides a solid base for securing the punching tooling, as well as a wide range of optional and custom designed tooling.



IW-100S

Capacities and Specifications

Unit: mm

MODEL	IW-60S IW-60SD	IW-80S IW-80SD	IW-100S IW-100SD	IW-125S IW-125SD	IW-165SD
PUNCHING					
Punching Force	60 Ton	80 Ton	100 Ton	125 Ton	165 Ton
Punch Capacity (Diameter x Thickness)	ø22 x 20 ø50 x 9	ø26 x 22 ø50 x 12	ø28 x 26 ø50 x 15	ø33 x 27 ø50 x 18	ø37 x 32 ø50 x 24
Throat Depth	S: 310 SD: 510	310 510	310 510	310 510	-- 510
Maximum Stroke Length	100	100	100	100	100
Cycles / Min. (20mm stroke)	30	29	28	28	29
Working Height Up to Die	1010	1050	1044	1069	1050
ANGLE SHEARING					
At 90° Shearing	130 x 130 x 12	150 x 150 x 12	150 x 150 x 15	150 x 150 x 15	200 x 200 x 20
At 45° Miter Shearing	65 x 65 x 8	75 x 75 x 9	75 x 75 x 9	75 x 75 x 9	75 x 75 x 9
Working Height	1115	1165	1216	1185	1185
FLAT SHEARING					
Flat Bar Shear (Width x Thickness)	350 x 15 240 x 20	460 x 15 300 x 20	610 x 16 400 x 20	610 x 18 400 x 25	760 x 20 400 x 30
Blade Length	360	465	620	620	770
Angle Flange Trim	100	100	100	100	120
Working Height	910	926	954	920	920
BAR SHEARING					
Round Bar Shear	ø40	ø45	ø45	ø50	ø60
Square Bar Shear	38 x 38	45 x 45	45 x 45	50 x 50	60 x 60
Channel Shear (H x B)	125 x 65*	150 x 75*	150 x 75*	150 x 75*	200 x 90*
IBeam Shear (H x B)	--	150 x 75*	150 x 75*	150 x 75*	200 x 100*
Working Height	1220	1270	1332	1310	1370
NOTCHING					
Rectangular Notcher (W x D x T)	50.8 x 90 x 9	50.8 x 90 x 12	63.5 x 90 x 12	63.5 x 90 x 13	63.5 x 90 x 16
Vee-Notcher (Side x Side x T)	90 x 90 x 10*	90 x 90 x 12*	105 x 105 x 12*	105 x 105 x 13*	105 x 105 x 16*
Working Height	910	926	954	920	920
SPECIAL TOOLING					
Large Vee-Notcher (Side x Side x T)	145 x 145 x 8*	145 x 145 x 10*	145 x 145 x 12*	145 x 145 x 12*	145 x 145 x 12*
Single Vee Press Brake (W x T)	250 x 12*	250 x 12*	250 x 15*	250 x 20*	250 x 20*
Multi Vee Press Brake (W x T)	500 x 5*	500 x 5*	700 x 5*	700 x 5*	700 x 5*
Angle Bending	100 x 100 x 7*	100 x 100 x 7*	100 x 100 x 13*	100 x 100 x 13*	100 x 100 x 13*
Pipe Notching	ø100*	ø100*	ø100*	ø100*	ø100*
OTHER					
Electric Power (HP)	7.5 HP	10 HP	10 HP	15 HP	20HP
Net Weight (Appr.)	S: 1780 kg SD: 2060 kg	2120 kg 2550 kg	2880 kg 3340 kg	3300 kg 3900 kg	-- 5180 kg
Gross Weight (Appr.)	S: 1890 kg SD: 2230 kg	2250 kg 2760 kg	3050 kg 3600 kg	3530 kg 4160 kg	-- 5480 kg
Machine Dimension (Appr.)	S: 1700 x 800 x 1710 SD: 2070 x 800 x 1710	1830x820x1760 2220x820x1730	2100x860x1810 2460x860x1810	2170x1030x1850 2490x1030x1850	-- 2710x1070x2010
Packing Dimension (Appr.)	S: 1930 x 900 x 1940 SD: 2290 x 900 x 1950	2070x940x1960 2450x960x1985	2350x950x2100 2700x1000x2060	2430x1150x2070 2730x1150x2100	-- 2940x1210x2270

* : Optional Tooling

Note: Based on low carbon / mild steel material strength of 45kg / mm² tensile.

Design and specifications subject to change without notice.

A 2-hole overhang die holder and a 2-piece gauging table are provided as standard equipment on all dual cylinder ironworkers.

PM SERIES

Hydraulic Punching Machine

- The patented dual-piston hydraulic cylinder enables the machine to retract faster, and also makes our cylinder slimmer, which brings a better appearance to the machine.
- Punching machines ranging from 35 to 200 tons of punching capacities, combined with different throat depths to choose from, provides a complete range of models to meet our customer's wide range of requirements.
- All optional tooling used on the punching station of S/SD ironworkers can also be used on the PM models, turning the punching machine into a universal machine.



*Bar shearing.



*Channel shearing.



*Angle shearing.

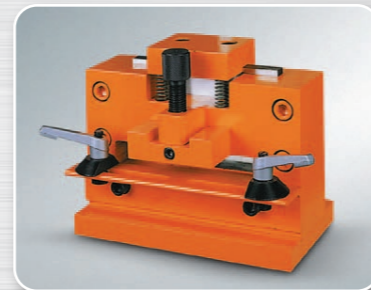

*Flat bar shearing.



*Rectangular notcher.



PM-55LT

Capacities and Specifications

Unit: mm

MODEL	PM-35T PM-35LT PM-35XT	PM-55T PM-55LT PM-55XT	PM-80T PM-80LT PM-80XT	PM-120LT PM-120XT	PM-160LT PM-160XT	PM-200LT PM-200XT
PUNCHING						
Punching Force	35 Ton	55 Ton	80 Ton	120 Ton	160 Ton	200 Ton
Punch Capacity (Diameter x Thickness)	ø18 x 14 ø50 x 5	ø22 x 18 ø50 x 8	ø25 x 23 ø50 x 12	ø32 x 27 ø50 x 17	ø36 x 32 ø50 x 23	ø41 x 35 ø50 x 29
Throat Depth	T: 310 LT: 510 XT: 760	310 510 760	310 510 760	-- 510 760	-- 510 760	-- 510 760
Maximum Stroke Length	100	100	100	100	100	100
Cycles/Min. (20mm stroke)	41	28	28	26	27	28
Table Size (W x D)	T: 700 x 500 LT: 700 x 700 XT: 700 x 950	700 x 500 700 x 700 700 x 950	700 x 500 700 x 700 700 x 950	-- 700 x 700 700 x 950	-- 700 x 700 700 x 950	-- 700 x 700 700 x 950
Working Height Up to Die	1050	1050	1050	1050	1050	1050
OPTIONAL TOOLING						
Largest Hole*	ø160 x 2	ø160 x 3	ø160 x 4	ø160 x 5	ø160 x 6.5	ø160 x 8
Single Vee Press Brake (W x T)*	250 x 12	250 x 12	250 x 12	250 x 20	250 x 20	250 x 20
Multi Vee Press Brake (W x T)*	500 x 3	500 x 5	500 x 5	700 x 5	700 x 5	700 x 5
Angle Bending*	65 x 65 x 8	75 x 75 x 6	100 x 100 x 7	100 x 100 x 13	100 x 100 x 13	100 x 100 x 13
Rectangular Notcher (WxDxT)*	63.5 x 90 x 5	63.5 x 90 x 6	63.5 x 90 x 8	63.5 x 90 x 10	63.5 x 90 x 10	63.5 x 90 x 10
Vee Notcher (Side x Side x T)*	145 x 145 x 4	145 x 145 x 6	145 x 145 x 10	145 x 145 x 12	145 x 145 x 12	145 x 145 x 12
Pipe Notcher (Max diameter)*	ø100	ø100	ø100	ø100	ø100	ø100
Flat Bar Shearing*	175 x 5	175 x 7	175 x 10	175 x 14	175 x 14	175 x 14
Angle Shearing*	65 x 65 x 8	75 x 75 x 6	100 x 100 x 7	100 x 100 x 13	100 x 100 x 13	100 x 100 x 13
Round Bar Shearing*	ø28	ø32	ø32	ø32	ø32	ø32
Square Bar Shearing*	28 x 28	32 x 32	32 x 32	32 x 32	32 x 32	32 x 32
Channel Shearing (H x B)*	--	100 x 50	100 x 50	100 x 50	100 x 50	100 x 50
OTHER						
Electric Power	5 HP	5 HP	7.5 HP	10 HP	15 HP	20 HP
Net Weight (Appr.)	T: 1160 kg LT: 1450 kg XT: 1810 kg	1390 kg 1750 kg 2450 kg	1720 kg 2080 kg 2800 kg	-- 2950 kg 4380 kg	-- 3640 kg 4700 kg	-- 4780 kg 5720 kg
Gross Weight (Appr.)	T: 1300 kg LT: 1610 kg XT: 1980 kg	1540 kg 1920 kg 2630 kg	1870 kg 2260 kg 3000 kg	-- 3140 kg 4600 kg	-- 3900 kg 5060 kg	-- 5100 kg 6150 kg
Machine Dimension (Appr.) (L x W x H)	T: 1090x820x1770 LT: 1420x820x1795 XT: 1820x820x1815	1160x820x1960 1520x820x1960 1920x820x1960	1280x865x1980 1620x865x1980 2045x865x1980	-- 1720x970x2035 2170x940x2035	-- 1870x1040x2070 2370x1040x2135	-- 1975x1065x2095 2475x1065x2175
Packing Dimension (Appr.) (L x W x H)	T: 1330x940x2000 LT: 1650x950x2020 XT: 2060x980x2100	1400x940x2200 1770x940x2200	1530x1000x2200 1870x990x2205 2250x1000x2270	-- 1980x1060x2290 2440x1220x2250	-- 2080x1150x2280 2630x1160x2420	-- 2150x1400x2400 2515x1395x2360

* : Optional Tooling

Note: Based on low carbon / mild steel material strength of 45kg / mm² tensile.
Design and specifications subject to change without notice.

A 2-hole overhang die holder and a 2-piece gauging table are provided as standard equipment on all punching machines.